

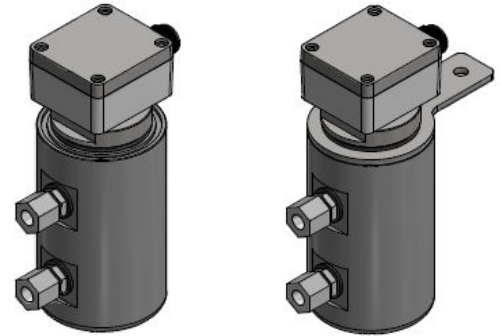

GENERAL CHARACTERISTICS

Caged float liquid level switch designed for side mounting to a tank, with N.1 or 2 electrical SPDT contact. Reliable, compact and easy to install by the standard compression-fittings. The standard cage is in anodized aluminum, but stainless steel version is available too. Rugged construction with low maintenance need.

- **Stainless steel – AISI 316 float and stem**
- **Anodized aluminum cage – External side mounting**
- Easy mounting by the compression-fitting standard connection
- Hermetic SPDT reed switches
- S1 = N.1 switch / M2 = N.2 switches
- Operating ambient temperature -30 / +55 °C - 90% R.H.
- Minimum degree of protection IP65.
- Available certified constructions



TECHNICAL DATA

Tab.1

		Description				Code
Float	AISI 316	Ø 41x35 mm	P.S. 0,66	12 bar	S41	
Rod material	AISI 316				S	
Cage	Aluminum	Black anodized	Standard		CAL-D	
Bypass chamber	AISI 316	-	On request		CAL-S	
Process connection Side / Side	1/4" UNI 228/1 female thread		Basic		Ø8G	
	Center distance - 55 mm		Standard		55	
	Fittings Ø 10 mm. pipe union		Standard		10	
Contacts N	S1	M2	SPDT	230V 60W 60VA 1A	7	
Electrical housing	Aluminum – epoxy painted PG9 polyamide cable gland		IP 65 protection		K1	
Max. temperature °C	105°C				L	
Sealing gasket	OR-NBR gasket anti-oil		Standard		4	
	OR-VITON gasket		On request		5	

HOUSING - mm.

Tab.2

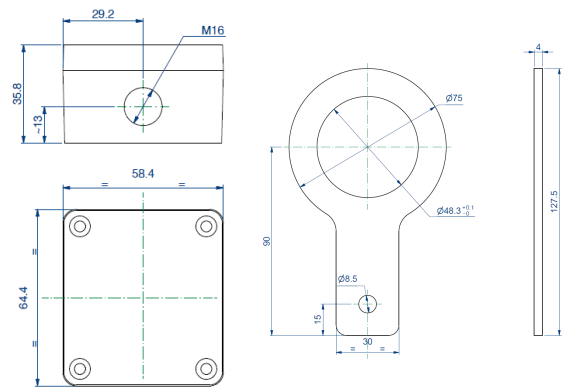

OPTION: Mounting bracket B

DIMENSIONS - mm.

Tab.3

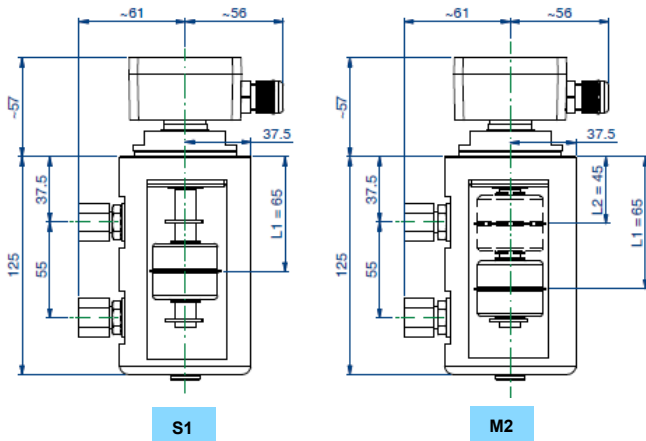

WIRING

Tab.4

I = Independent 3 = SPDT

Contacts status in no level condition

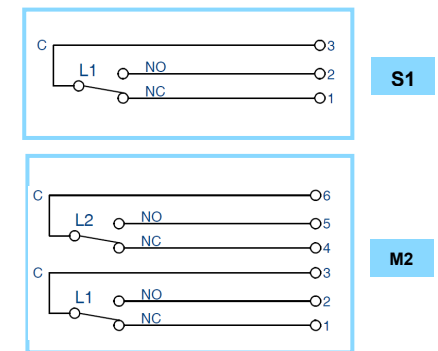

L1 and L2 switch level point, see drawings Tab.3

NOMENCLATURE

S1	S41	7	CAL-D	S	55/10	K1	B	L	4	I3
•										
	•									
		•								
			•							
				•						
					•					
						•				
							•			
								•		
									•	
										•

Tab.1-3-4	S1 one switch level point (L1) / M2 two switch level point (L1..L2)
Tab.1	Float
Tab.1	Electrical contact
Tab.1	Cage, bypass chamber series - Cage material
Tab.1	Rod material
Tab.1	Side-side centre distance process connections / Pipe size
Tab.1	Electrical output
Tab.2	Mounting bracket – on request
Tab.1	Temperature class
Tab.1	Sealing gasket
Tab.4	Wiring